



TECHNICAL DATA

8169
4CX3000A
RADIAL-BEAM
POWER TETRODE

The EIMAC 8169/4CX3000A is a ceramic/metal power tetrode designed to be used as a Class AB1 linear amplifier in audio or radio-frequency applications.

The tube is also recommended for use as a Class C rf power amplifier and plate-modulated rf power amplifier. It is forced-air cooled, with a maximum anode dissipation rating of 3500 watts.

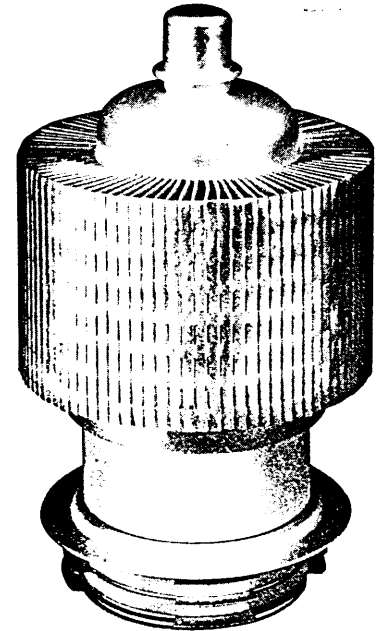

GENERAL CHARACTERISTICS1

ELECTRICAL

Filament: Thoriated Tungsten

Table with 3 columns: Parameter, Value, and Unit. Includes rows for Voltage (9.0 ± 0.45 V), Current (41.5 A), Amplification Factor (5.5), Frequency for Maximum Ratings (150 MHz), and various capacitance values (Cin, Cout, Cgp, Cpk).

- 1. Characteristics and operating values are based upon performance tests. These figures may change without notice as the result of additional data or product refinement. Eimac should be consulted before using this information for final equipment design.
2. Capacitance values are for a cold tube as measured in a special shielded fixture in accordance with Electronic Industries Association Standard RS-191.

MECHANICAL

Base . . . . . Special ring and breechblock terminal surfaces





Maximum Operating Temperature:

Ceramic/Metal Seals and Anode Core .....	250°C
Recommended Air System Socket .....	EIMAC SK-1400 series
Recommended Air Chimney .....	EIMAC SK-1406
Operating Position .....	Axis vertical, base up or down

Maximum Overall Dimensions:

Length .....	7.90 In; 20.07 cm
Diameter .....	4.62 In; 11.73 cm
Cooling .....	Forced Air
Net Weight .....	5.5 lb; 2.5 kg

RADIO-FREQUENCY POWER AMPLIFIER OR OSCILLATOR

Class-C Telegraphy or FM (Key-down conditions)

ABSOLUTE MAXIMUM RATINGS:

DC PLATE VOLTAGE .....	7000 VOLTS
DC SCREEN VOLTAGE .....	1000 VOLTS
DC PLATE CURRENT .....	2.0 AMPERES
PLATE DISSIPATION .....	3000 WATTS
SCREEN DISSIPATION .....	175 WATTS
GRID DISSIPATION .....	50 WATTS

TYPICAL OPERATION

Plate Voltage .....	5000	7000 Vdc
Screen Voltage .....	500	500 Vdc
Grid Voltage .....	-280	-300 Vdc
Plate Current .....	1.9	1.9 Adc
Screen Current <sup>1</sup> .....	250	230 mAdc
Grid Current <sup>1</sup> .....	100	100 mAdc
Peak RF Grid Voltage <sup>1</sup> .....	385	405 v
Driving Power <sup>1</sup> .....	39	41 W
Plate Dissipation .....	1900	2300 W
Plate Output Power .....	7600	11,000 W

1. Approximate value.

PLATE-MODULATED RADIO-FREQUENCY POWER AMPLIFIER

Class-C Telephony (Carrier Conditions unless noted)

ABSOLUTE MAXIMUM RATINGS:

DC PLATE VOLTAGE .....	5000 VOLTS
DC SCREEN VOLTAGE .....	600 VOLTS
DC PLATE CURRENT .....	1.4 AMPERES
PLATE DISSIPATION <sup>2</sup> .....	2000 WATTS
SCREEN DISSIPATION .....	175 WATTS
GRID DISSIPATION .....	50 WATTS

TYPICAL OPERATION

Plate Voltage .....	5000 Vdc
Screen Voltage .....	500 Vdc
Peak AF Screen Voltage (For 100% Modulation) <sup>1</sup> .....	415 v
Grid Voltage .....	-375 Vdc
Plate Current .....	1.4 Adc
Screen Current <sup>1</sup> .....	170 mAdc
Grid Current <sup>1</sup> .....	68 mAdc
Peak RF Grid Voltage <sup>1</sup> .....	455 v
Grid Driving Power <sup>1</sup> .....	31 W
Plate Dissipation .....	1250 W
Plate Output Power .....	5750 W

1. Approximate value.

2. Corresponds to 3000 watts at 100 % sine-wave mod.

AUDIO-FREQUENCY AMPLIFIER OR MODULATOR

Class-AB

ABSOLUTE MAXIMUM RATINGS (Per Tube)

DC PLATE VOLTAGE .....	6000 VOLTS
DC SCREEN VOLTAGE .....	1000 VOLTS
DC PLATE CURRENT .....	2.0 AMPERES
PLATE DISSIPATION .....	3500 WATTS
SCREEN DISSIPATION .....	175 WATTS
GRID DISSIPATION .....	50 WATTS

TYPICAL OPERATION (Two Tubes), Class AB 1

Plate Voltage .....	5000	6000 Vdc
Screen Voltage .....	850	850 Vdc
Grid Voltage <sup>1</sup> .....	-180	-200 Vdc
Max-Signal Plate Current .....	3.6	3.1 Adc
Zero-Signal Plate Current .....	1.0	0.7 Adc
Max-Signal Screen Current <sup>2</sup> .....	170	120 mAdc
Zero-Signal Screen Current <sup>2</sup> .....	0	0 mAdc
Peak AF Driving Voltage <sup>1,2</sup> .....	155	175 v
Driving Power .....	0	0 W
Load Resistance, Plate-to-Plate .....	3000	4160 Ω
Max-Signal Plate Dissipation <sup>1</sup> .....	3300	3100 W
Max-Signal Plate Output Power .....	11,400	12,400 W

1. Per Tube.

2. Approximate values.

**RADIO-FREQUENCY LINEAR AMPLIFIER**

Class AB

TYPICAL OPERATION Class AB<sub>1</sub>, Grid Driven

## ABSOLUTE MAXIMUM RATINGS:

DC PLATE VOLTAGE	7000 VOLTS
DC SCREEN VOLTAGE	1000 VOLTS
DC PLATE CURRENT	2.0 AMPERES
PLATE DISSIPATION	3500 WATTS
SCREEN DISSIPATION	175 WATTS
GRID DISSIPATION	50 WATTS

Plate Voltage	5000 Vdc
Screen Voltage	850 Vdc
Grid Voltage	-180 Vdc
Zero-Signal Plate Current	0.5 Adc
Single-Tone Plate Current	1.65 Adc
Single-Tone Screen Current <sup>1</sup>	25 mAdc
Two-Tone Plate Current <sup>1</sup>	1.10 Adc
Two-Tone Screen Current <sup>1</sup>	20 mAdc
Peak RF Grid Voltage <sup>1</sup>	155 v
Driving Power	0 W
Peak Envelope Useful Output Power <sup>1</sup>	5300 W
Intermodulation Distortion Products (without negative feedback) 3rd Order	-35 dB
5th Order	-40 dB

1. Approximate values.

NOTE: TYPICAL OPERATION data are obtained from direct measurement or by calculation from published characteristic curves. Adjustment of the rf grid voltage to obtain the specified plate current at the specified bias, screen and plate voltages is assumed. If this procedure is followed, there will be little variation in output power when the tube is changed, even though there may be some variation in grid and screen current. The grid and screen currents which result when the desired plate current is obtained are incidental and vary from tube to tube. These current variations cause no difficulty so long as the circuit maintains the correct voltage in the presence of the variations in current. In the case of Class C Service, if grid bias is obtained principally by means of a grid resistor, the resistor must be adjustable to obtain the required bias voltage when the correct rf grid voltage is applied.

**RANGE VALUES FOR EQUIPMENT DESIGN**

	<u>Min.</u>	<u>Max.</u>
Filament Current, at 9:0 volts	39.5	43.5 A
Interelectrode Capacitance (grounded cathode) <sup>1</sup>		
C <sub>in</sub>	120	140 pF
C <sub>out</sub>	10.5	14.5 pF
C <sub>gp</sub>	---	1.40 pF
Interelectrode Capacitance (grounded grid) <sup>1</sup>		
C <sub>in</sub>	55.0	67.0 pF
C <sub>out</sub>	10.5	14.5 pF
C <sub>pk</sub>	---	0.20 pF
Grid Voltage (E <sub>b</sub> = 2000 Vdc; E <sub>c2</sub> = 750 Vdc; adjust for I <sub>b</sub> = 1000 mAdc)	-95	-127 Vdc
Grid Cut off Voltage (E <sub>b</sub> = 4000 Vdc; E <sub>c2</sub> = 850 Vdc; adjust for I <sub>b</sub> = 1.0 mAdc)	---	-310 Vdc

1. Capacitance values are for a cold tube as measured in a special shielded fixture in accordance with Electronic Industries Association Standard RS-191.

**APPLICATION****MECHANICAL**

**MOUNTING** - The 4CX3000A must be operated with its axis vertical. The base of the tube may be down or up at the convenience of the circuit designer.

**SOCKETING** - The EIMAC sockets, type SK-1400A and SK-1470A, have been designed especially for the base of the 4CX3000A. The SK-1400A has no contacts grounded to the socket shell and has an integral screen grid bypass capacitor of 1800 pF, with a 1000 DCWV rating.



The SK-1470A has no bypass capacitor and the screen grid contacts are directly grounded to the socket shell.

The use of recommended air-flow rates through these sockets provides effective forced-air cooling of the tube. Air forced into the bottom of the socket passes over the tube terminals through the Air Chimney SK-1406, and through the anode cooling fins.

**COOLING** - The maximum temperature rating for the external surfaces of the 4CX3000A is 250°C. Sufficient forced-air circulation must be provided to keep the temperature of the anode at the base of the cooling fins and the temperature of the ceramic/metal seals below 250°C. Air-flow requirements to maintain seal temperature at 200°C in 40°C ambient air are tabulated below (for operation below 30 megahertz).

Plate Dissipation* (Watts)	SEA LEVEL		10,000 FEET	
	Air Flow (CFM)	Pressure Drop (In. of Water)	Air Flow (CFM)	Pressure Drop (In. of Water)
1500	36.5	0.3	53	0.4
2500	60	0.8	88	1.2
3500	86	1.6	125	2.3

\* Since the power dissipated by the filament represents about 450 watts and since grid-plus-screen dissipation can, under some conditions, represent another 225 watts, allowance has been made in preparing this tabulation for an additional 675 watts dissipation.

The blower selected in a given application must be capable of supplying the desired air flow at a back pressure equal to the pressure drop shown above plus any drop encountered in ducts and filters.

At other altitudes and ambient temperatures the flow rate must be modified to obtain equivalent cooling. The flow rate and corresponding pressure differential must be determined individually in such cases, using rated maximum temperatures as the criteria for satisfactory cooling.

## ELECTRICAL

**FILAMENT OPERATION** - The peak emission at rated filament voltage of the EIMAC 4CX3000A is normally many times the peak emission required for communication service. A small decrease in filament temperature due to reduction of filament voltage can increase the life of

the 4CX3000A by a substantial percentage. It is good practice to determine the nominal filament voltage for a particular application that will not affect the operation of the equipment. This is done by measuring some important parameter of performance such as plate current, power output, or distortion while filament voltage is reduced on the 4CX3000A. At some point in filament voltage there will be a noticeable reduction in plate current, or power output, or an increase in distortion. Operation may be at a filament voltage slightly higher than that point at which performance appears to deteriorate. This voltage should be measured at the socket with a 1% meter and periodically checked to maintain proper operation.

**GRID OPERATION** - The 4CX3000A grid has a maximum dissipation rating of 50 watts. Precautions should be observed to avoid exceeding this rating. The grid bias and driving power should be kept near the values shown in the "Typical Operation" sections of the data sheet whenever possible. The maximum grid circuit resistance should not exceed 100,000 ohms per tube.

**SCREEN OPERATION** - The power dissipated by the screen of the 4CX3000A must not exceed 175 watts.

Screen dissipation, in cases where there is no ac applied to the screen, is the simple product of the screen voltage and the screen current. If the screen voltage is modulated, the screen dissipation will depend upon loading, driving power, and carrier screen voltage.

Screen dissipation is likely to rise to excessive values when the plate voltage, bias voltage, or plate load are removed with filament and screen voltages applied. Suitable protective means must be provided to limit the screen dissipation to 175 watts in the event of circuit failure.

**PLATE DISSIPATION** - The plate-dissipation rating for the 4CX3000A is 3500 watts. When it is operated as a plate-modulated rf amplifier, under carrier conditions, the maximum plate dissipation is 2000 watts.

**FAULT PROTECTION** - In addition to normal cooling airflow interlock and plate and screen over-current interlocks, it is good practice to protect the tube from internal damage which could result from occasional plate arcing at high plate voltage.



In all cases some protective resistance, at least one or two ohms, should be used in series with the tube anode to absorb power supply stored energy in case a plate arc should occur. Where stored energy is high, it is recommended that some form of electronic crowbar be used which will discharge power supply capacitors in as short a time as possible following indication of start of a plate arc.

**HIGH VOLTAGE** - Normal operating voltages used with the 4CX3000A are deadly, and the equipment must be designed properly and operating precautions must be followed. Design all equipment so that no one can come in contact with high voltages. All equipment must include safety enclosures for high-voltage circuits and terminals, with interlock switches to open primary circuits of the power supply and to discharge high-voltage condensers whenever access doors are opened. Interlock switches must not be bypassed or "cheated" to allow operation with access doors open. Always remember that HIGH VOLTAGE CAN KILL.

**X-RAY RADIATION HAZARD** - High vacuum tubes operating at voltages higher than 15 kV produce progressively more dangerous x-ray radiation as the voltage is increased. This tube, operating at its rated voltages and currents, is a potential x-ray hazard. Only limited shielding is afforded by the tube envelope.

Moreover, the x-ray radiation level may increase significantly with aging and gradual deterioration, due to leakage paths or emission characteristics as they are effected by the high voltage. X-ray shielding must be provided on all sides of a tube operating at these voltages to provide adequate protection throughout the tube's life. The amount of shielding required will vary with tube usage and therefore is beyond Varian's control.

Periodic checks on the x-ray level should be made and the tube should never be operated without adequate shielding in place. Lead glass attenuates x-rays and is available for viewing windows. If there is any doubt as to the adequacy of the shielding, an expert in this field should be contacted to perform an x-ray survey of the equipment.

Useful information on this subject can be found in Reports 33 and 39 of the National Council on Radiation Protection, 7910 Woodmont Ave., Suite 1016, Bethesda, MD 20814; telephone (301) 657-2652.

Operation of high voltage equipment with interlock switches rendered inoperative and cabinet doors open

in order to better locate an equipment malfunction can result in serious x-ray exposure.

The amount of x-ray radiation is dependent upon the particular tube operating conditions. When tested per EIA TEPA Publication #181, the maximum radiation measured 12 inches from the tube surface is 31.5 R/Min.

**INTERELECTRODE CAPACITANCE** - The actual internal interelectrode capacitance of a tube is influenced by many variables in most applications, such as stray capacitance to the chassis, capacitance added by the socket used, stray capacitance between tube terminals, and wiring effects. To control the actual capacitance values within the tube, as the key component involved, the industry and the Military Services use a standard test procedure as described in Electronic Industries Association Standard RS-191. This requires the use of specially constructed test fixtures which effectively shield all external tube leads from each other and eliminates any capacitance reading to "ground". The test is performed on a cold tube. Other factors being equal, controlling internal tube capacitance in this way normally assures good interchangeability of tubes over a period of time, even when the tube may be made by different manufacturers. The capacitance values shown in the manufacturer's technical data, or test specifications, normally are taken in accordance with Standard RS-191.

The equipment designer is therefore cautioned to make allowance for the actual capacitance values which will exist in any normal application. Measurements should be taken with the socket and mounting which represent approximate final layout if capacitance values are highly significant in the design.

**SPECIAL APPLICATION** - if it is desired to operate this tube under conditions widely different from those listed here, write to CPI, Eimac Division, 301 Industrial Way, San Carlos CA 94070 for information and recommendations.

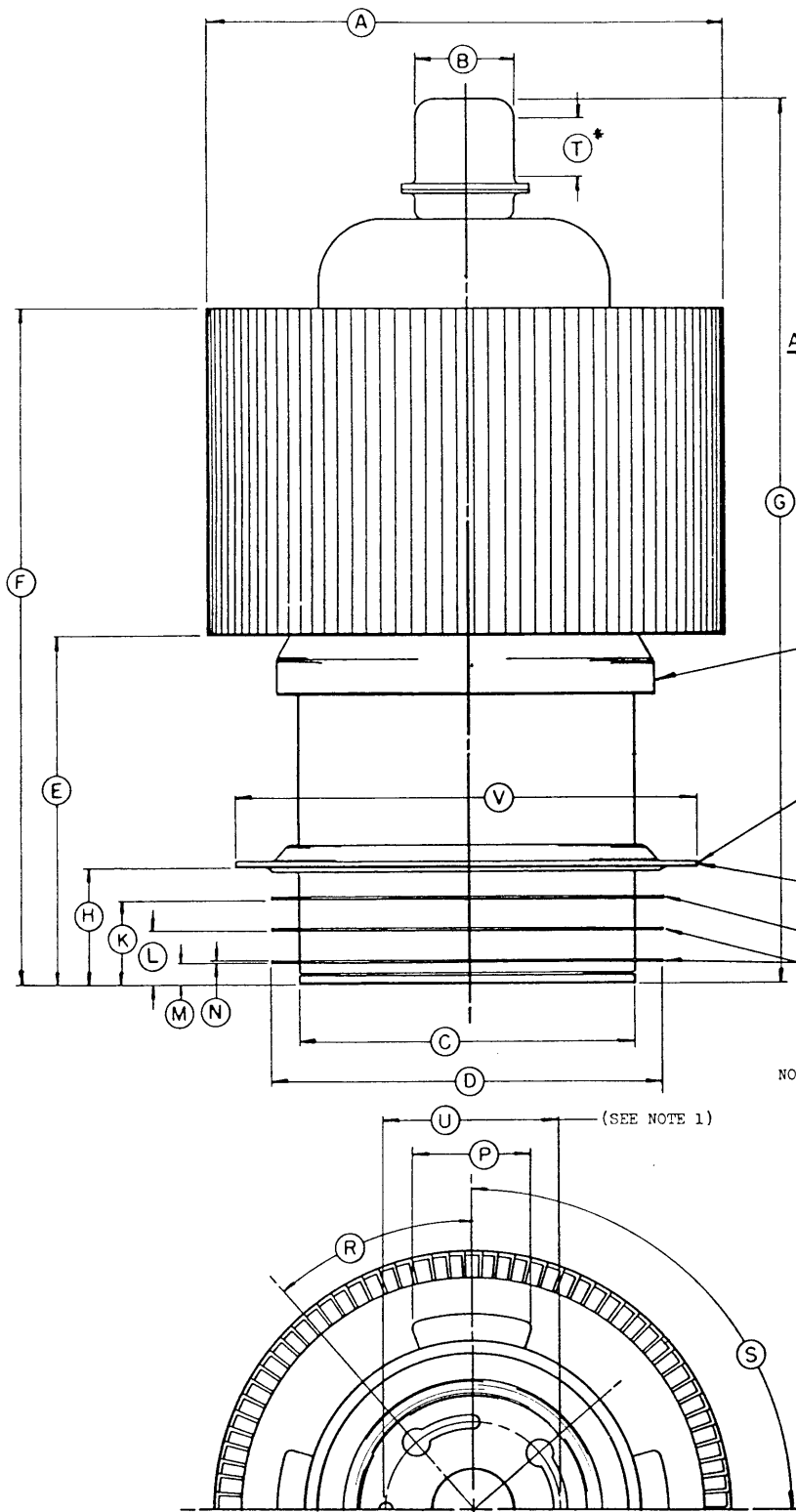

DIM	DIMENSIONAL DATA					
	INCHES			MILLIMETERS		
	MIN.	MAX.	REF.	MIN.	MAX.	REF.
A	4.560	4.625	- -	115.82	117.48	- -
B	0.860	0.890	- -	21.84	22.61	- -
C	- -	3.050	- -	- -	77.44	- -
D	3.490	3.550	- -	88.65	90.17	- -
E	2.875	3.125	- -	73.03	79.38	- -
F	5.875	6.125	- -	149.23	155.58	- -
G	7.600	7.900	- -	193.04	200.66	- -
H	0.965	1.005	- -	24.51	25.53	- -
K	0.700	0.730	- -	17.78	18.54	- -
L	0.430	0.460	- -	10.92	11.68	- -
M	0.160	0.180	- -	4.06	4.57	- -
N	0.018	0.025	- -	0.46	0.64	- -
P	1.050	1.150	- -	26.67	29.21	- -
R	39°	41°	- -	39°	41°	- -
S	89°	91°	- -	89°	91°	- -
T	0.485	- -	- -	12.32	- -	- -
U	1.557	1.567	- -	39.55	39.80	- -
V	4.000	4.175	- -	101.60	106.05	- -

ANODE

DO NOT CONTACT

DO NOT CONTACT O.D.

SCREEN GRID

CONTROL GRID

FILAMENT

NOTES:

1. TUBE BASE MUST ACCEPT A GAGE WITH FOUR PINS ON TRUE POSITION WITHIN .0005 R MOUNTED IN A BASE PLATE 1/4" THICK BY 3 1/4" DIA. EIMAC GAGE NO. GB 2104.



**EIMAC 4CX3000A  
IM DISTORTION VS.  
POWER OUTPUT**

(As function of zero-signal  
plate current)

$E_b = 5000$  Volts,  $E_{c2} = 850$  Volts

$R_L = 1700$  Ohms,  $F_1 = 1.980$  MHz

$F_2 = 1.982$  MHz

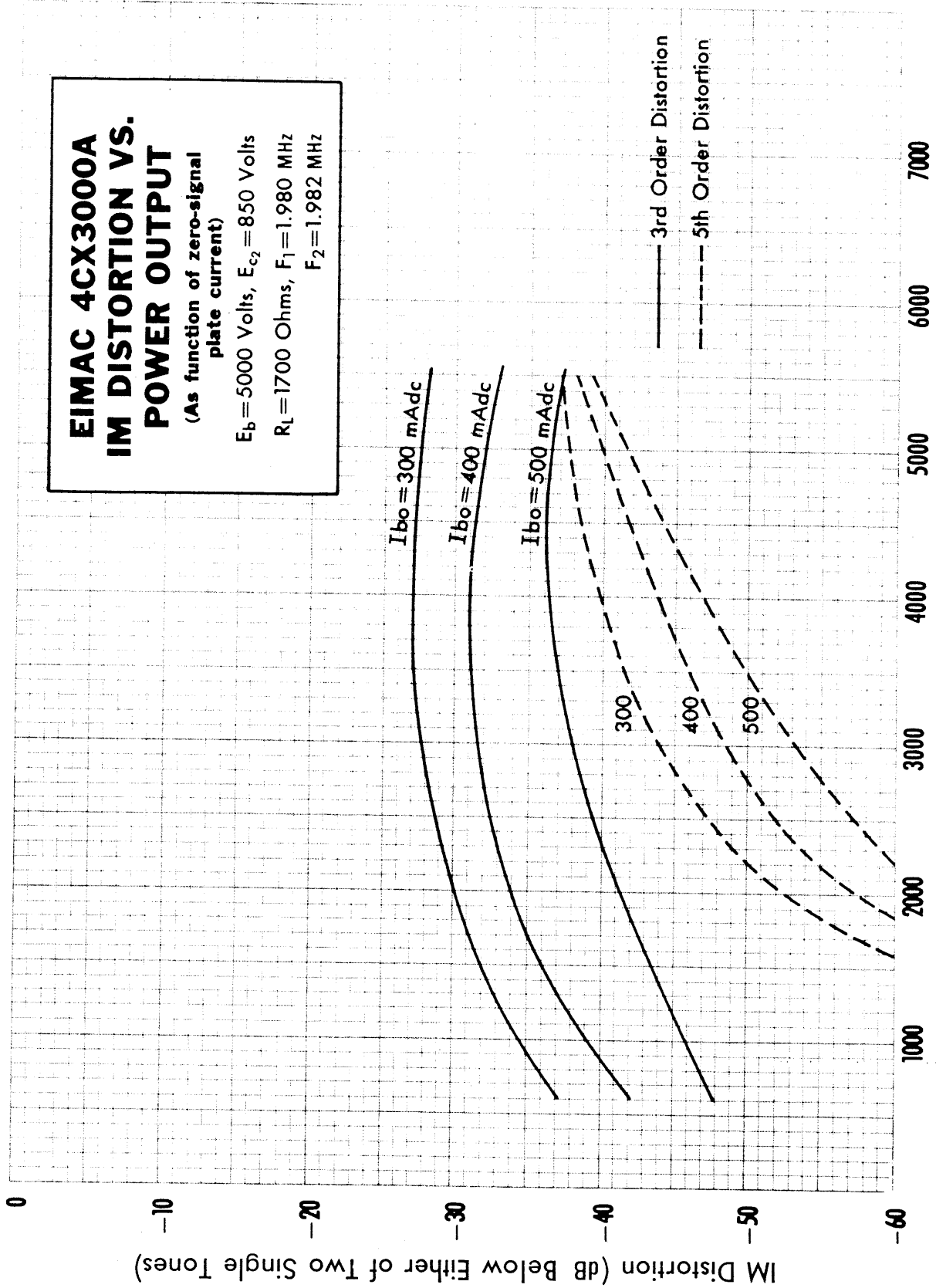



# EIMAC 4CX3000A TYPICAL CONSTANT CURRENT

SCREEN VOLTAGE = 500 VOLTS

- PLATE CURRENT — AMPERES
- - - SCREEN CURRENT — AMPERES
- - - - GRID CURRENT — AMPERES

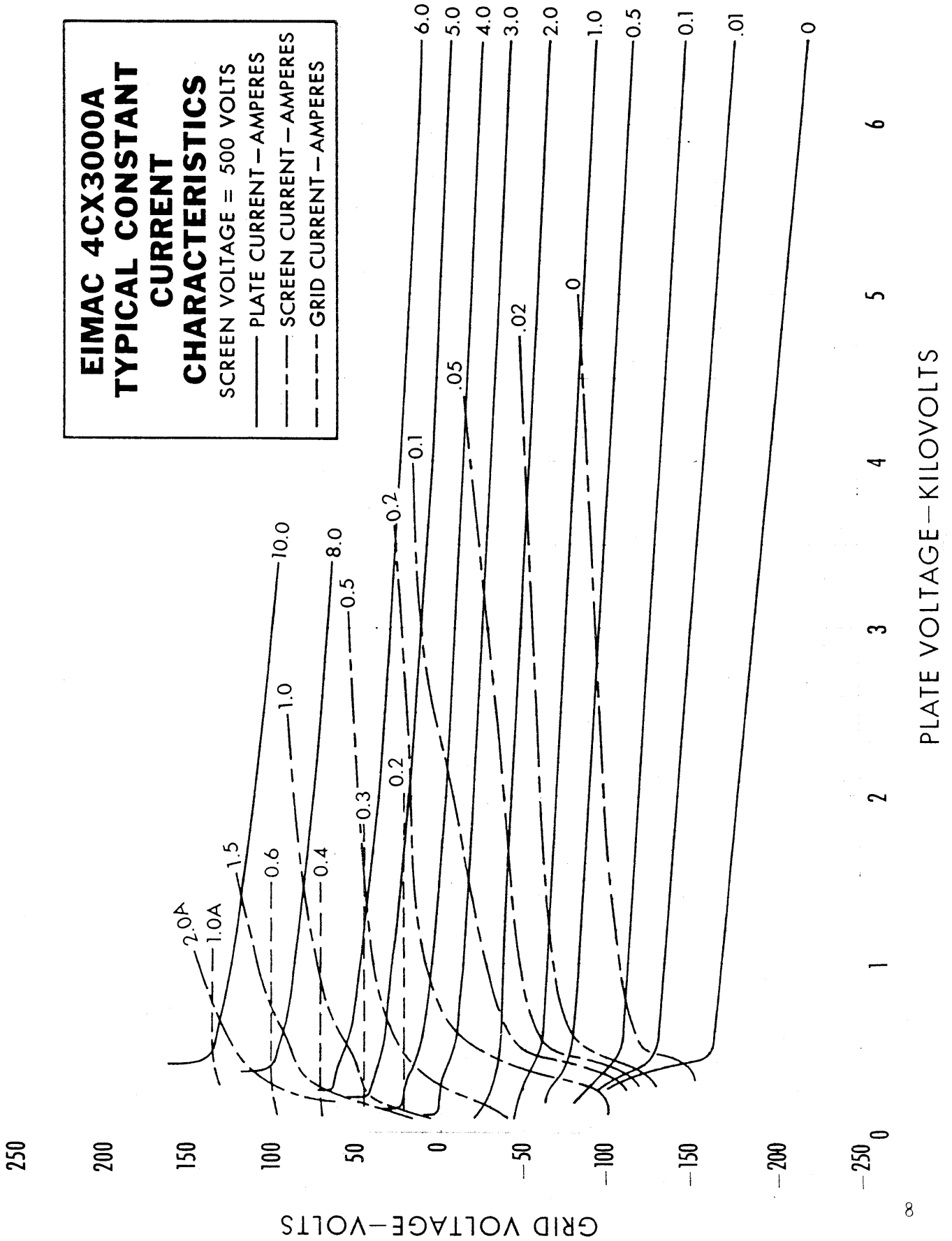



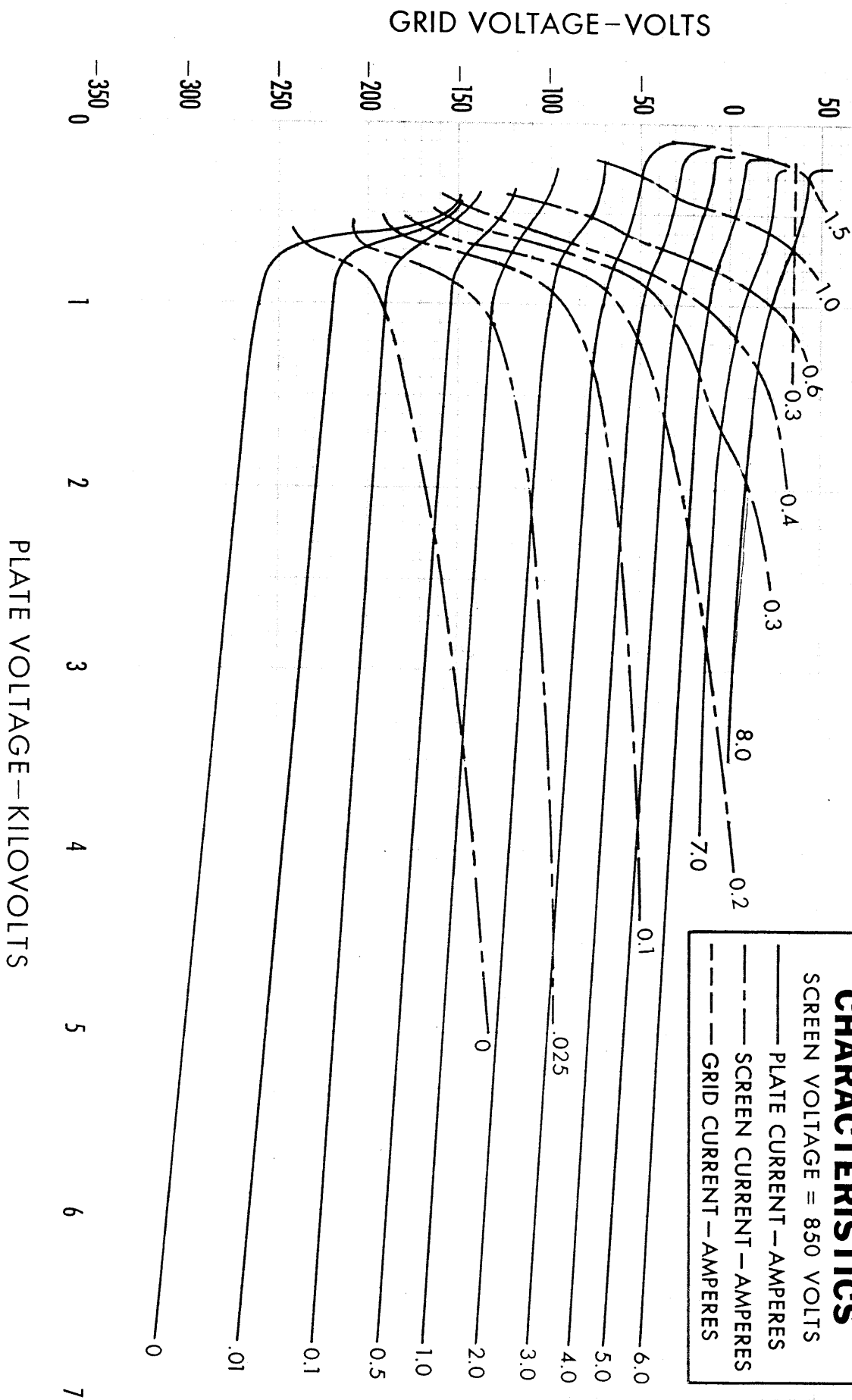

**EIMAC 4CX3000A**  
**TYPICAL CONSTANT**  
**CURRENT**  
**CHARACTERISTICS**  
SCREEN VOLTAGE = 850 VOLTS  
——— PLATE CURRENT — AMPERES  
- - - - SCREEN CURRENT — AMPERES  
- · - · - GRID CURRENT — AMPERES